

### Thermal Design of the LEDs

#### 1. Reasons to have Good Thermal Design

When designing a product using LEDs, it is important to account for the heat generated by the LEDs. The ambient temperature that the LED can be used in is determined by the junction temperature ( $T_j$ ).

The LEDs may become dim, or not even illuminate if the  $T_j$  goes above the absolute maximum ratings specified in the specification sheet. It is important to have a good thermal design as keeping the  $T_j$  as low as possible will lengthen the life of the LED. This application note will contain information on how to have a good thermal design.

#### 2. Path of the heat

Figure 1 is an example of how the heat can pass through the LED. It is believed that the heat is transmitted to the air by going through the die bond, electrodes, solder, and the board.

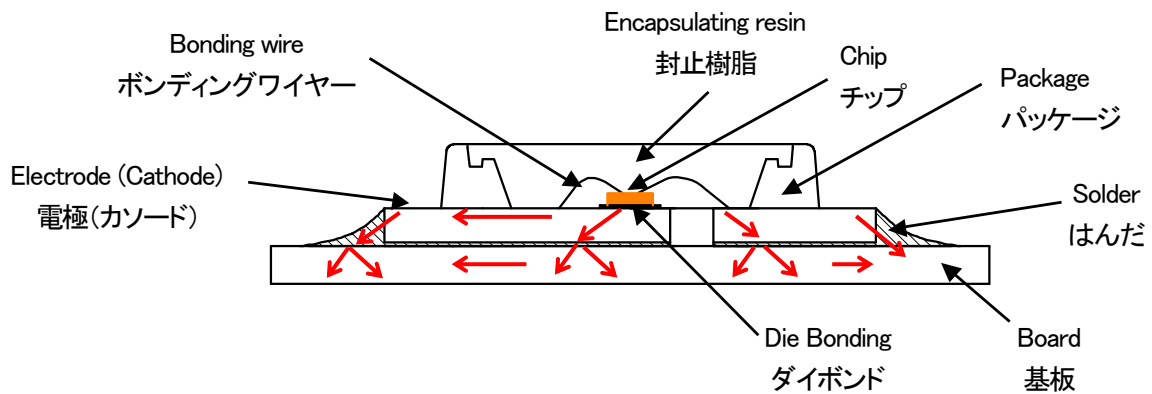

Figure 1 LED's structure and an example of the heat path (Example LED Model: NS3W183)

Figure 2 indicates a flow chart of the heat from the chip.

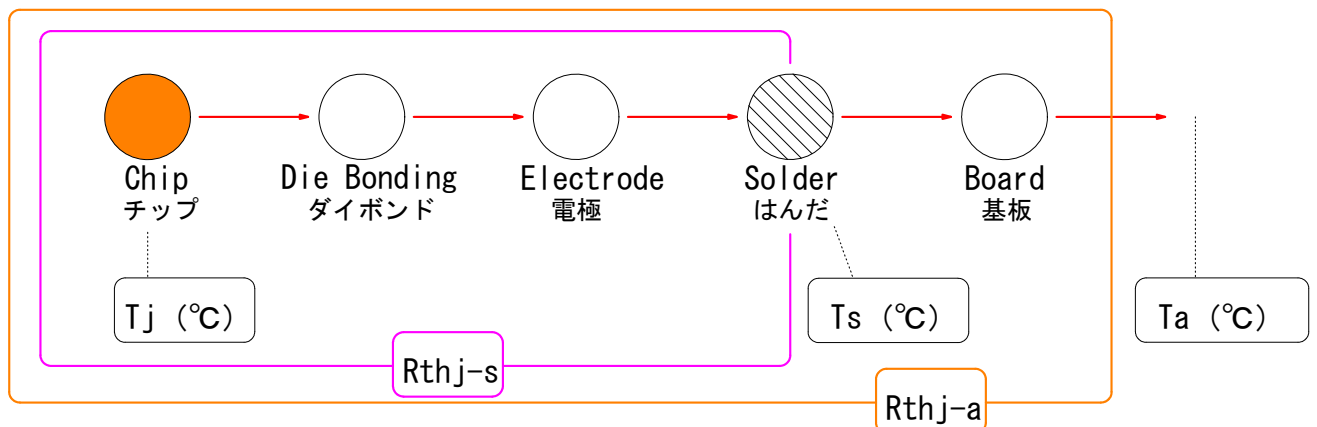

Figure 2 Flow chart of the heat from the chip

If the change in temperature from the chip is expressed as the thermal resistance ( $^{\circ}\text{C} / \text{W}$ ), two equations can be written with regards to  $T_j$ .

This sheet contains tentative information, we may change contents without notice.

(1) If using the value of the thermal resistance ( $R_{thj-a}$ ) from the chip to Ambient temperature:

$$T_j = T_a + R_{thj-a} \times W \quad \textcircled{1}$$

- $T_a$ : Ambient temperature (°C)
- $R_{thj-a}$ : Thermal Resistance from Chip to ambient (°C/W)
- $W$ : Input power consumption (=  $I_f \times V_f$ ) (W)  
( $I_f$ : Forward current,  $V_f$ : Forward voltage)

(2) If using the value of the thermal resistance ( $R_{thj-s}$ ) from the chip to Soldering temperature:

$$T_j = T_s + R_{thj-s} \times W \quad \textcircled{2}$$

- $T_s$ : Soldering temperature (Cathode side) (°C)
- $R_{thj-s}$ : Thermal Resistance from the chip to  $T_s$  measuring point (°C/W)
- $W$ : Input power consumption (=  $I_f \times V_f$ ) (W)  
( $I_f$ : Forward current,  $V_f$ : Forward voltage)

### 3. Calculating $T_j$

There are two methods to calculate  $T_j$

- (A) Calculating  $T_j$  by the  $T_s$  measurement
- (B) Calculating  $T_j$  by the  $V_f$  measurement method

Details are shown below.

#### (A) Calculating $T_j$ by measuring $T_s$

(1) Attach a thermocouple to the  $T_s$  measurement point (cathode side) of the mounted LED.

Turn on the LED and measure the temperature  $T_s$ ,  $I_f$  and  $V_f$  when the LED has reached the thermal equilibrium state.

※The  $T_s$  measurement point and  $R_{thj-s}$  may vary according to the products. Please confirm it in our specifications.

※Please use the thinnest thermocouple possible to minimize the measurement interference.

The connection of the thermocouple should be done by soldering.

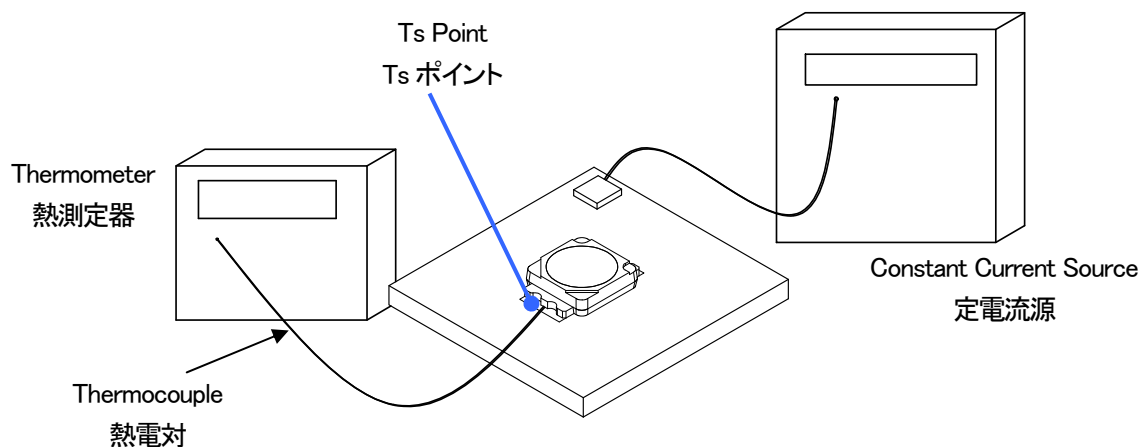

Figure 3 Thermal Measuring Set Up

(2) The  $T_j$  can be calculated using equation  $\textcircled{2}$  with the measured values of  $T_s$ ,  $I_f$  and  $V_f$ .

This sheet contains tentative information, we may change contents without notice.

(B) Calculating  $T_j$  by measuring  $V_F$

(1) The LED's forward voltage ( $V_F$ ) is measured at a specific increment of ambient temperature ( $T_a$ ) using a thermostatic chamber.

※The measurement is taken in a windless environment.

※Pulse current is used when measuring the LEDs to keep the  $V_F$  stable from being affected by its own heat generation.

(Recommendation: Pulse width <10ms, Duty ratio < 1/10)

(2) Making a graph of Ambient Temperature vs Forward Voltage from the measurement result (1).

(※We can consider  $T_a \doteq T_j$  in a thermal equilibrium state.)

※Example: Figure 4 indicates the ambient temperature vs forward voltage properties for NS3W183.

(3) In a windless environment, turn on the LED with DC and measure the  $V_F$  once it is in a thermal equilibrium state.

(4) The  $T_j$  can be calculated by the  $V_F$  measured, using the ambient temperature vs. forward voltage graph.

[Example]

At  $V_F=3.41(V)$ , the  $T_j$  is  $50^\circ C$  as show in Figure 5.

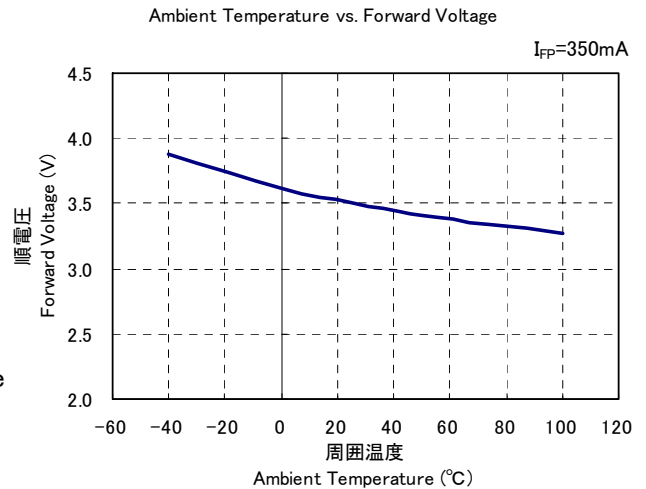

Figure 4 Ambient Temperature vs. Forward Voltage (NS3W183)

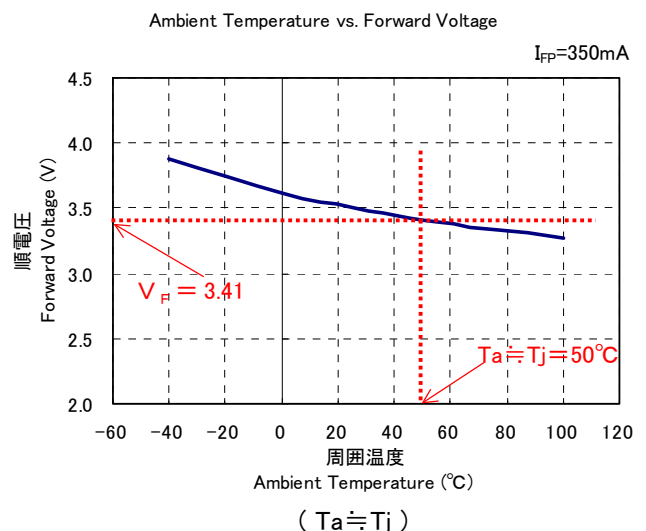

Figure 5 Calculation of  $T_j$  (NS3W183)

#### 4. Thermal Design

When designing a product, the  $T_j$  can be lowered by implementing methods to lower the thermal resistance of the product as a whole.

Example:

- (A) Choice of board materials
- (B) Optimization of the copper foil area of the board
- (C) Optimization of the LED placement (LED pitch)
- (D) Implementing heat sinks

Details of each are explained below.

### (A) Choice of board materials

Printed circuit boards can be classified as resin, metal-based, or ceramic as shown in Figure 6.

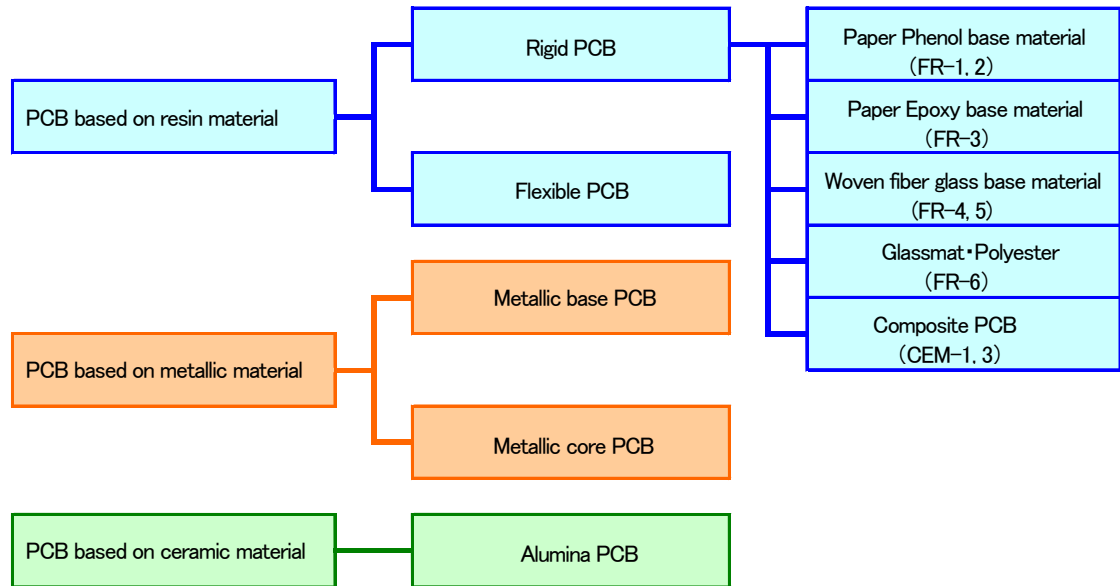
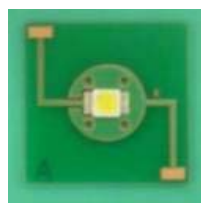
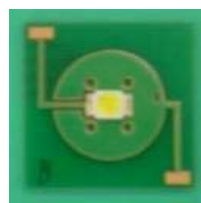
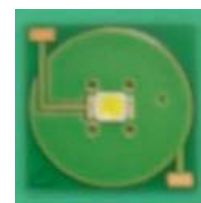
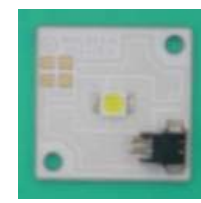

Figure 6 Classification of Printed Circuit Boards

Woven fiber based material (FR-4) boards are commonly used due to their cost and their dimension consistency. However, by using a metal-based board a higher thermal conductivity can be achieved and will lower the T<sub>j</sub> of the LED. As a reference, Table 1 and Figure 7 show the thermal measurement results with a FR-4 and with an aluminum board.

Table 1 Thermal Measurement Results for NS6W183

				
	Type A	Type B	Type C	Type D
Main Material	FR-4			Aluminum
R <sub>thj-a</sub> [°C/W]	63	50	44	34
PWB Size	30mm × 30mm, t=1.6mm			30mm × 30mm, t=1.7mm
Copper Area Face	154mm <sup>2</sup> , t=0.07mm	302mm <sup>2</sup> , t=0.07mm	616mm <sup>2</sup> , t=0.07mm	500mm <sup>2</sup> , t=0.07mm
Copper Area Back	154mm <sup>2</sup> , t=0.07mm	302mm <sup>2</sup> , t=0.07mm	616mm <sup>2</sup> , t=0.07mm	–
I <sub>F</sub> (mA)	700			
V <sub>F</sub> (V)	3.18	3.24	3.29	3.30
T <sub>s</sub> (°C)	143	118	95	80
T <sub>j</sub> (°C)	165	141	118	103

※Measurement condition : R<sub>thj-s</sub>=10°C/W, T<sub>a</sub>=25°C, Thermo Couple: Φ0.076mm

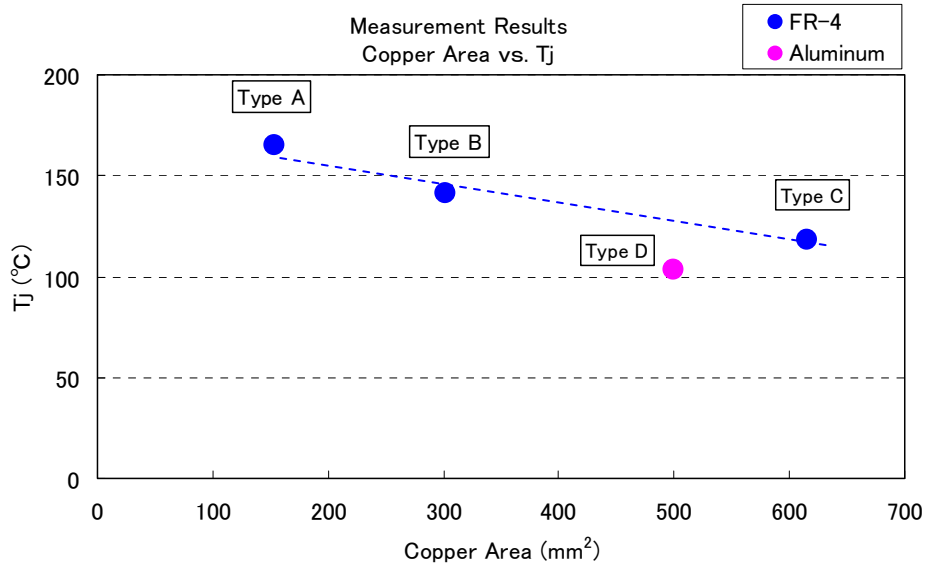

Figure 7 Thermal Measurement Results for NS6W183 (Copper area vs Tj)

Assuming that the board sizes are the same, it is clear from the measurements above that the T<sub>j</sub> is lower on the aluminum board compared to the FR-4 board.

### (B) Optimization of the copper foil area of the board

To transfer the heat generated by the chip to the board as much as possible, it is recommended to increase the thermal conductive area by increasing the area of the copper foil as shown in Figure 8.

Table 1 and Figure 7: The value of the T<sub>j</sub> falls as the copper foil area increases.

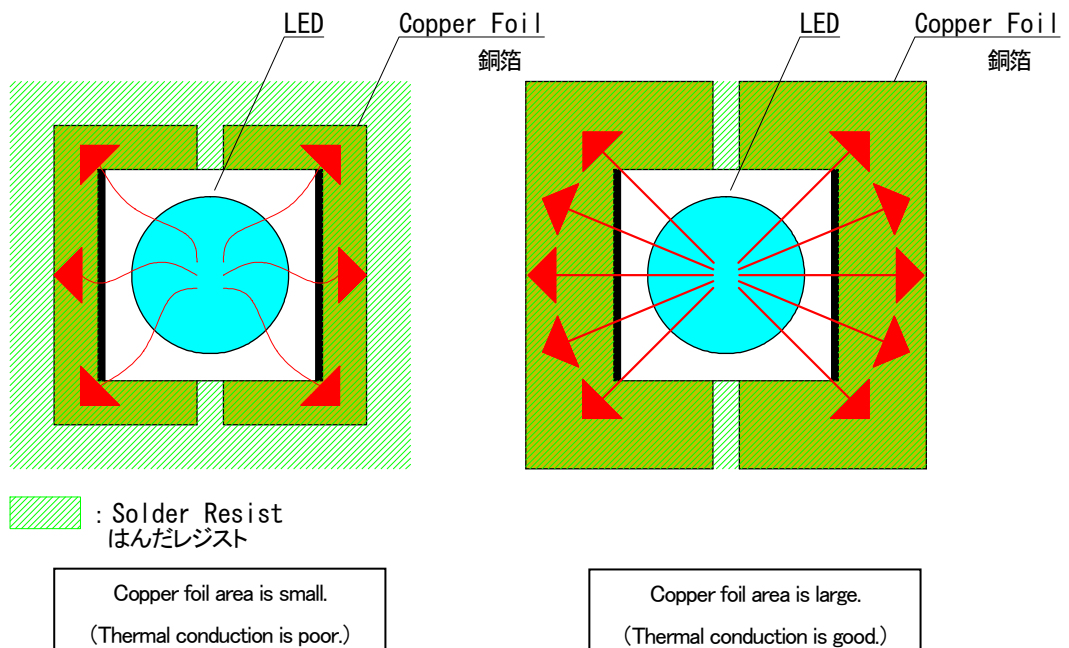

Figure 8 Copper foil pattern shape of the printed circuit board

(C) Optimization of the LED placement (LED pitch)

If the LED pitch becomes too narrow as shown in Figure 9, it becomes harder to radiate the heat generated in a concentrated area.

Figure 10 shows the heat distribution simulation with various LED pitches.

It can be seen that the heat is trapped when the LED pitch is narrow. By increasing the LED pitch as much as possible, the  $T_j$  could be lowered.

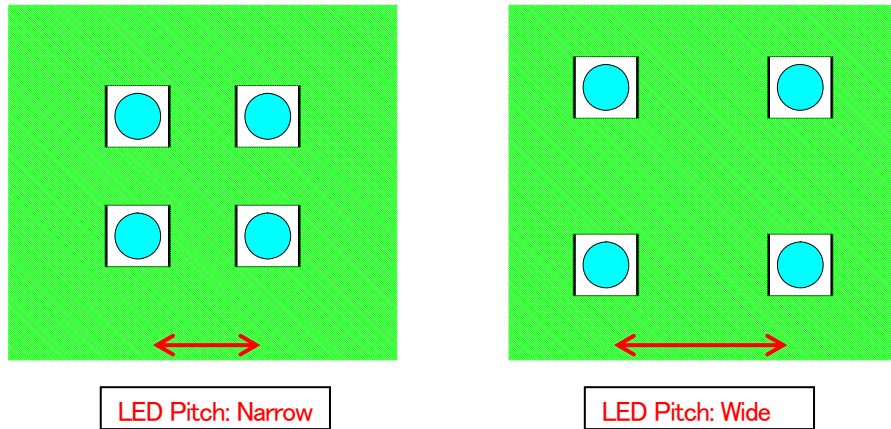

Figure 9 LED Placement

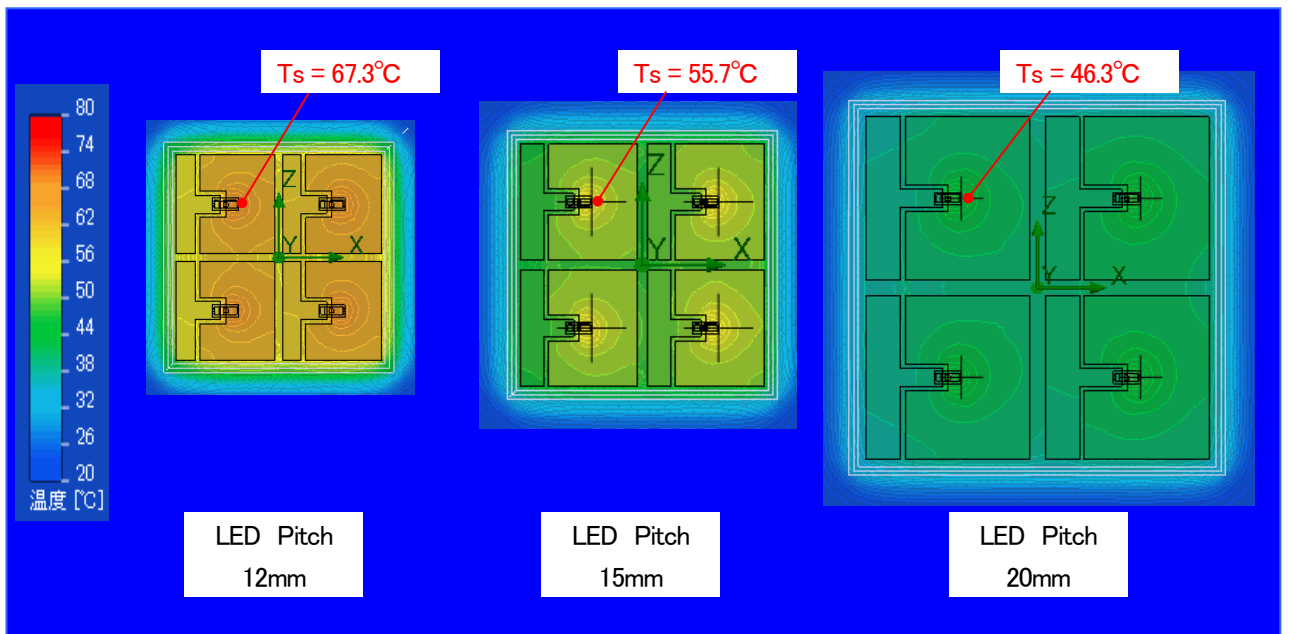

Figure 10 Thermal distribution simulation results (Example: NSSW157)

※Since the simulation is set to have the copper foil area as large as possible in order to have the widest LED pitch, the copper foil area will be different for each simulation.

### (D) Implementing a heat sink

The heat radiation efficiency can be improved by attaching a heat sink to the back side of the board.

Table 3 shows the measurement results with or without a heat sink. Both  $R_{thj-a}$  and  $T_j$  are lower when a heat sink is attached.

To further improve the heat radiation efficiency, it is recommended to attach the heat sink to the board using a thermally conductive tape, sheet, or grease.

Examples of connecting a heat sink to the board are shown in Figure 11.

Table 3 Thermal measurement results with the heat sink for NS6W183.

	without Heat Sink	with Heat Sink
Main Material	FR-4	
$R_{thj-a}$ [ $^{\circ}C/W$ ]	44	32
PWB Size	30mm × 30mm, t=1.6mm	
Copper Area	616mm <sup>2</sup> , t=0.07mm	
$I_F$ (mA)	700	
$V_F$ (V)	3.29	3.49
$T_s$ ( $^{\circ}C$ )	95	73
$T_j$ ( $^{\circ}C$ )	118	97

※Measurement condition :  $R_{thj-s}=10^{\circ}C/W$ ,  $T_a=25^{\circ}C$ , Thermo Couple:  $\Phi 0.076mm$

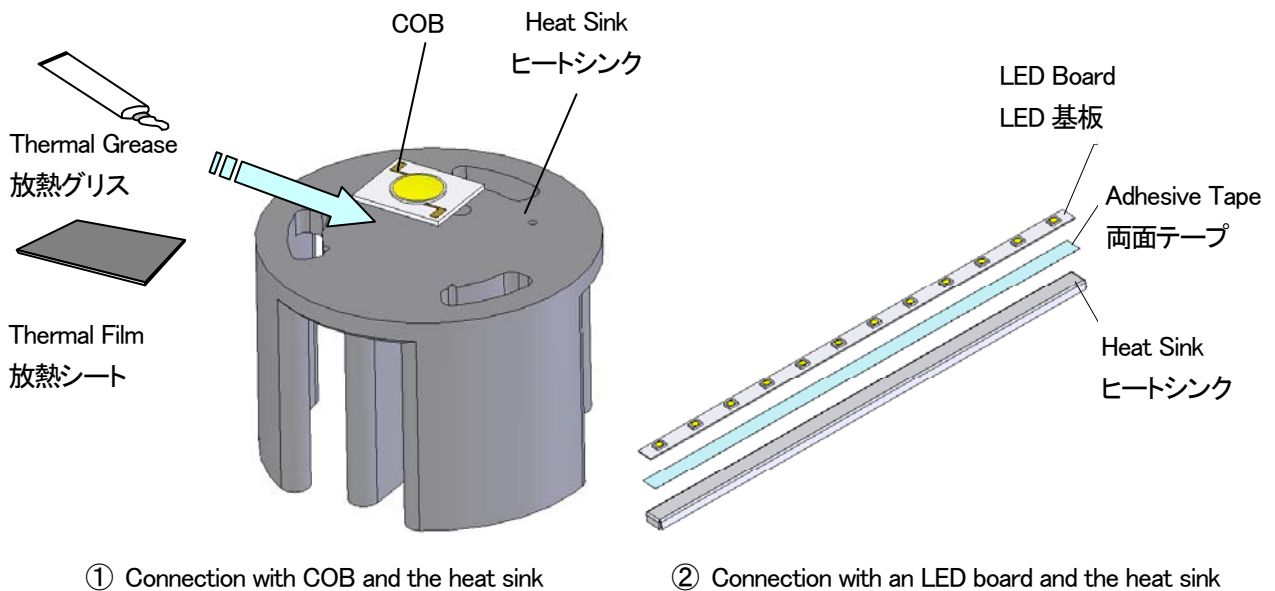

Figure 11 Connection with the board and the heat sink

### 5. Summary

By following the thermal designs mentioned in this application note, LEDs can be more efficiently used and thereby potentially improve the reliability of the end product.

This sheet contains tentative information, we may change contents without notice.